

OPTIMIZATION OF THE HEATING OF A METAL
BY AN ELECTRIC ARC

P. F. Bulyanyi and S. P. Polyakov

UDC 537.523.5

We investigate and generalize the results of experimental measurements of heat fluxes in a metal anode from a plasma jet of a plasmatron with an external arc (PEA) whose operating conditions vary over a wide range.

In plasma-mechanical treatment (PMT) of metals [1-3] a problem sometimes encountered is that of intensification in the heating of a cut-off layer of a billet by an electric arc stabilized by a gas vortex and the walls of the PEA nozzle. The essence of the technological process is that the metal subjected to compression by the cutting tool is heated by an electric arc, one of whose electrodes is the billet itself. In what follows, we shall mean by the term "optimization of the heating of the metal" the choice of such conditions of combustion for the electric arc that the effective coefficient of heating of the metal (the efficiency) $\eta = Q_{e1}/IU$ will be maximum. The choice of optimal operating conditions for the PEA enables us to maximize the productivity of metal treatment, increase the purity of the treated surface, and make maximum use of the technological possibilities of the PMT process for metals.

The measurement of heat fluxes entering the metal anode has been investigated in a number of studies [4-6]. However, the experimental data given in these cannot be used for intensifying the process of heating because it is impossible to obtain from them a correlation formula for the heat flux. Using the results of theoretical and calculated investigations [7, 8] on heat fluxes in metal is impossible because of the large error (up to 300%) resulting from the fact that the experimental conditions are not identical. It should be noted that the combustion of the arc with maximum effective efficiency of heating of the metal is not the only factor determining the effectiveness of the process of heat treatment of the metal. It is also necessary that the efficiency of the PEA be the maximum possible, that the work resource of the cathode be sufficiently high, that the electric arc retain its spatial stability, and that the rules of safety technology be observed. Experience in working with PEAs (with argon as the working gas) has shown that its efficiency is fairly high (92-96%) and that the work resource of a tungsten cathode is several hundred hours [9]. An argon arc, for the conditions of present investigations, retains its spatial stability at gas flow rates not less than 10^{-4} kg/sec. The noise does not exceed 60 dB, and the arc combustion voltage is 180 V, i.e., the rules of safety technology are observed.

To optimize the heating of the metal by the electric arc, we must make clear the fundamental parameters affecting the process of heat transfer from the PEA to the material being treated and establish a mathematical relation between them. At present this problem has not been solved.

The purpose of this study is the experimental investigation and generalization of heat fluxes in a metal anode from the electric arc of a PEA whose design parameters vary over a wide range: $d = (4-10) \cdot 10^{-3}$ m, $h = (0-14) \cdot 10^{-3}$ m, and the diameter of the calibrated tungsten cathode is $(5-7) \cdot 10^{-3}$ m. In the experiments, we used the generally accepted scheme for measuring heat fluxes which is described in [5]. However, the sensor for measuring the heat fluxes was itself completely different in design from the one described in [5].

As the sensor for measuring the heat fluxes entering the anode, we used a rotating calorimeter (Fig. 1), consisting of two coaxially mounted tubes between which cooling water flows. The outer tube is made of copper, and the positive pole of the electrical power source for the arc is fed to it through contact brushes. The inner tube is made of a thermally insulating material, namely, plastic. In order to reduce the thermal inertia of the

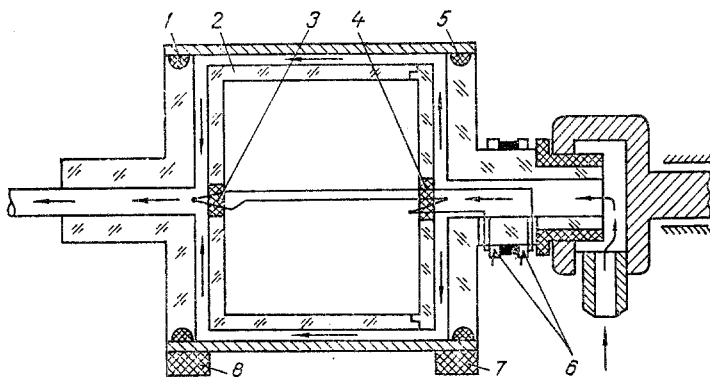

Fig. 1. Scheme of rotating calorimeter with flow-through coolant for measuring heat fluxes entering the anode: 1) heat-absorbing copper surface; 2) hollow insert; 3, 4) junctions of differential thermocouple; 5) packing; 6) contact rings; 7, 8) brushes.

calorimeter, the junctions of a differential thermocouple are set up in its interior at the minimum possible distance from the site of the heating, and the outputs of the thermocouple are joined to the contact rings. The calibration of the inner thermocouple was carried out with the calorimeter rotating, using the readouts of a nonrotating calibrated thermocouple whose junctions were situated near the junctions of the first thermocouple, at the water outlet and inlet.

We did not observe any boiling of the water under the heated surface of the calorimeter for any of the conditions investigated; this is confirmed by the absence of any sharp jumps in the thermocouple signal. Using an experimental and computational method [10, 11], we determined the time constant of the calorimeter (1.1 sec), its sensitivity threshold for a water flow rate of $20 \cdot 10^{-3}$ kg/sec (40 W), the upper limit of measurement of the heat fluxes ($45 \cdot 10^3$ W), and the minimum duration of one measurement (6 sec). The linear velocity of rotation of the sensor (1 m/sec) was calculated by the formula $V_0 = 2r_0/0.1\tau_0$, where τ_0 , the time up to the beginning of melting, is found from the formula [12]

$$\tau_0 = \left[\frac{t_p - t_0}{q} \right] \frac{\pi}{4\alpha}.$$

The values of the parameters r_0 and q are taken from [13].

In the experiments the heat fluxes were measured by calorimetry of the water cooling the heat-absorbing surface of the sensor, the cathode, and the nozzle of the PEA. The water flow rates were determined with RM-4 rotameters. We also recorded other parameters of the process: the gas flow rate, the current of the electric arc, and the voltage drop across it. The recording of the thermocouple signals, the current, and the voltage was carried out by means of a K-115 light-ray oscillograph.

In order to reduce the voltage pulsations of the power source feeding the electric arc, we included in its load circuit a smoothing filter which reduced the pulsations to 2.6% for a current of 200 A through the active load.

Because the calorimeter rotates during the measurements, there may be convective heat losses; taking these into account, on the basis of the criteria in the formula given in [14], we found that for $V = 1.5$ m/sec, $D = 0.1$ m, $t_1 = 20^\circ\text{C}$, and $t_2 = 50^\circ\text{C}$, they do not exceed 1%. The heat losses at the sensor surface by radiation, estimated from the data of [15], were less than 1%. The total error in the measurement of the heat fluxes into the calorimeter did not exceed 6%.

In order to generalize the results of the experimental investigations, we use the formula for the balance of energy at the metal anode, which is valid for a regime with a positive potential drop at the electrode [16-18]:

$$Q_{el} = G(h_s - h_a) + I \left(\frac{5}{2} \frac{kT_e}{e} + U_a + \varphi_a \right), \quad (2)$$

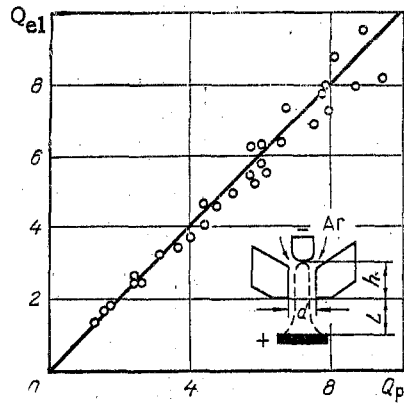

Fig. 2. Comparison of the heat fluxes entering the anode obtained from the Q_{e1} experiment and those calculated by formula (4). Q_{e1} , Q_p in kW.

from which it follows that the heat flux Q_{e1} must be proportional to the current of the electric arc. Furthermore, we took the diameter of the PEA nozzle, the depth to which the cathode was inserted into the nozzle, the length of the open part of the electric arc, and the gas flow rate as the determining parameters. For the conditions of the experiment it should be noted that the heat flux entering the metal anode is a monotone increasing function of L and h and a monotone decreasing function of G and d . It is therefore convenient to approximate the heat flux into the sensor by the following formula:

$$Q_p = A \frac{I^\alpha L^\beta}{G^\gamma d^\theta} (1 + Bh). \quad (3)$$

For the conditions of the experiment ($I = 80-500$ A, $U = 27-65$ V, $G = (0.4-2) \cdot 10^{-3}$ kg/sec, $h = (5-20) \cdot 10^{-3}$ m) we found that the coefficient values were the following: $A = 1.12 \cdot 10^{-2}$; $B = 450$; $\alpha = 1.63$; $\beta = 0.37$; $\gamma = 0.04$; $\theta = 0.87$. The final formula for the heat flux entering the sensor has the following form:

$$Q_p = 1.22 \cdot 10^{-2} \frac{I^{1.63} L^{0.37}}{G^{0.04} d^{0.87}} (1 + 450h). \quad (4)$$

For the calculations, all the quantities appearing in the expression are taken in the SI system (Q_p in W). With an error of up to 15%, we can calculate by formula (4) the heat flux entering the sensor from an electric arc stabilized by a gas vortex and the walls of the PEA nozzle. Figure 2 shows a comparison of the heat fluxes obtained by experiment and those calculated by formula (4), and the values are seen to be in fairly good agreement.

From the data of our investigation it follows that the effective voltage equivalent $U^* = Q_{e1}/I$ is a complicated function of I , L , h_s , G , and h . Unfortunately, an attempt to verify the suitability of the resulting calculation formula on the basis of data published by other authors [5, 6] was unsuccessful, since the published studies do not include all the parameters necessary for the calculation.

NOTATION

η , efficiency of heating of the metal; Q_{e1} , heat flux into the calorimeter; I , current of the electric arc; U , voltage drop across the electric arc; V , linear velocity of rotation of the sensor; r_0 , thermal radius of arc spot; τ_0 , time until surface of calorimeter begins to melt; t_p , melting point of copper; t_0 , initial temperature of calorimeter surface; q , specific heat flux in the heating spot; α , thermal diffusivity; D , diameter of rotating calorimeter; t_1 , temperature of surrounding medium; t_2 , temperature of the surface of the rotating calorimeter; G , argon flow rate; h_s , specific enthalpy of argon in the region near the anode; h_a , specific enthalpy of argon at the surface of the calorimeter; k , Boltzmann constant; T_e , electron temperature in the anode region; e , charge of the electron; U_a , potential drop at the anode; ϕ_a , work function of electrons leaving copper; L , length of open part of the arc — distance from the cut in the nozzle of the PEA to the sensor; h , depth of cathode insertion into the nozzle — distance from the cut in the PEA nozzle to the cathode; d , diameter of the PEA nozzle; U_a^* , effective voltage equivalent.

LITERATURE CITED

1. A. N. Stroshkov, Sh. L. Tesler, S. P. Shabashov, and D. S. Élinson, Cutting Treatment of Difficult-to-Work Materials with Heating [in Russian], Mashinostroenie, Moscow (1977).
2. S. P. Kravchenko, S. P. Polyakov, V. S. Él'kin, et al., "Plasma intensification of the process of cutting of metals," in: Brief Theses of the Reports at the Eighth All-Union Scientific-Industrial Conference on Electrophysical and Electrochemical Methods of Treatment, "El'fa-77" [in Russian], I. I. Polzunov TsKTI, Leningrad (1977), p. 280.
3. A. V. Donskoi and V. S. Klubnikin, Electroplasma Processes and Equipment in Machine Construction [in Russian], Mashinostroenie, Leningrad Branch, Leningrad (1979).
4. Zh. Zheenbaev, G. A. Kobtsev, R. I. Konavko, and V. S. Éngel'sht, "Investigation of the thermal, electrical, and erosion characteristics of a plasma anode," Izv. Sib. Otd. Akad. Nauk SSSR, Ser. Tekh. Nauk, No. 3, Issue 1, 3-6 (1973).
5. D. I. Vainboim and Zh. V. Ratmanova, "Energy characteristics of an arc burning in argon with a different degree of compression," Svarochnoe Proizvod., No. 5, 1-3 (1974).
6. V. N. Blinov and A. I. Pugin, "Investigation of the energy characteristics of a direct-action plasma generator with two gas inputs," Fiz. Khim. Obrab. Mater., No. 6, 54-61 (1968).
7. V. A. Nemchinskii and L. N. Peretts, "Anode layer of a high-current high-pressure arc," Zh. Tekh. Fiz., 47, No. 9, 1868-1875 (1977).
8. I. G. Panevin, I. P. Nazarenko, and A. V. Ershov, "Investigations of processes at the anode in high-current high-pressure discharges," in: Experimental Investigations of Plasmotrons [in Russian], Nauka, Novosibirsk (1977), pp. 340-357.
9. M. F. Zhukov, A. S. An'shakov, and G.-N. B. Dandaron, "Erosion of electrodes," in: Processes at the Electrode and Erosion of Electrodes in Plasmotrons [in Russian], Nauka, Siberian Section, Novosibirsk (1977), pp. 61-83.
10. G. M. Kondrat'ev, Thermal Measurements [in Russian], Mashgiz, Moscow-Leningrad (1957).
11. E. I. Ivlev and O. A. Nazarovskii, "Dynamic properties of thermal containers with moving coolant," Inzh.-Fiz. Zh., 35, No. 1, 41-47 (1978).
12. A. G. Shashkov, L. Kreichi, V. I. Krylovich, et al., Heat Exchange in an Electric-Arc Gas Heater [in Russian], Énergiya, Moscow (1974).
13. N. A. Shoek, "Investigation of the energy balance at the anodes of high-current arcs burning in an argon atmosphere," in: Modern Problems of Heat Exchange [in Russian], Énergiya, Moscow-Leningrad (1966), pp. 110-139.
14. S. S. Kutateladze and V. M. Borishanskii, Handbook of Heat Transfer [in Russian], Gosénergoizdat, Moscow (1959).
15. N. B. Lapko, A. A. Porotnikov, A. A. Polyakov, et al., Investigation of Radiant Fluxes from an Anode in Symmetric Discharge. Plasma Accelerators (L. A. Artsimovich, General Editor) [in Russian], Mashinostroenie, Moscow (1972), p. 312.
16. N. S. Merinov and V. A. Petrosov, "Measurement of the anode potential drop by a calorimetric method," Zh. Tekh. Fiz., 46, No. 6, 1278-1281 (1976).
17. M. F. Zhukov, A. S. Koroteev, and B. A. Uryukov, Applied Dynamics of Thermal Plasma [in Russian], Nauka, Novosibirsk (1975).
18. V. N. Blinov, A. I. Pugin, and N. N. Rykalin, "Integral radiation of a high-current dc arc in argon," Fiz. Khim. Obrab. Mater., No. 4, 11-15 (1970).